



# B&B NOW HAS MORE... WE'VE GOT THE CAPACITY!!

## Drag Race Pans:

All pans feature 100% jig welded construction including baffling and trap doors for oil control. Our unidirectional windage screen and built in scraper are included for additional HP gains. SBC pans are cleared for up to 3.875" stroke and BBC for 4.250". Each pan includes matched pickup and 12 pt fasteners for a complete kit.

Drag Race Pans	
Part #	Description
91078	SBC '80-85' passenger side dipstick
91087	SBC 2 piece seal for Chevelle and Camaro driver/dipstick
91088	SBC 2 piece seal fits most chassis.
91089	SBC 1 piece '87 and up. Fits most chassis
91487	BBC 2 piece for Chevelle and Camaro
91488	BBC 2 piece seal. Fits most chassis.
91489	BBC Gen 5/6 1 piece seal. Fits most chassis
91498	BBC 2 piece seal. Box pan for marine and truck pull.

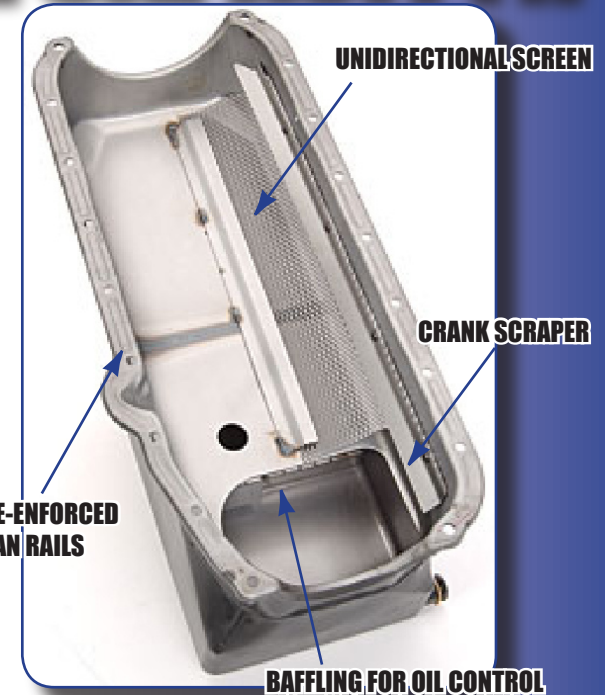

## Circle Track

All pans feature 100% jig welded construction including baffling and trap doors for oil control. Our unidirectional windage screen and built in scraper are included for additional HP gains. Both pans are cleared for up to 3.875" stroke. Each pan includes matched pickup and 12 pt fasteners for a complete kit.

Circle Track	
Part #	Description
93047	SBC 2 piece rear seal 7qt
93049	SBC 1 piece rear seal 7qt

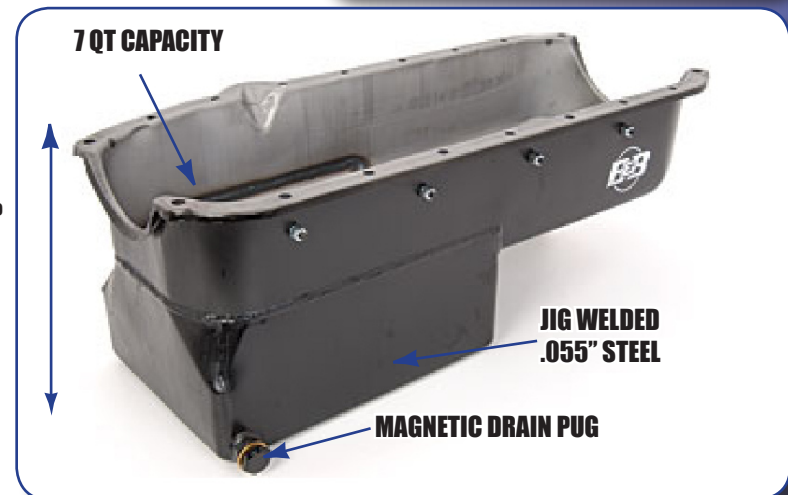

**B&B Performance Div. of Stef's Performance**  
693 Cross St. Lakewood, NJ 08701 | 732-364-6700